

# Parks

## Covid-19 Toolkit

### Covid-19 Guidance Posters

Use this guide to print and install Covid-19 messaging in public parks, beaches and recreational areas.

#### Posters to print from this toolkit:

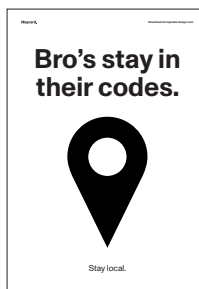

Display in popular destinations.

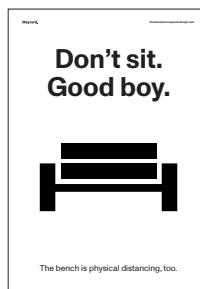

Display on public benches.

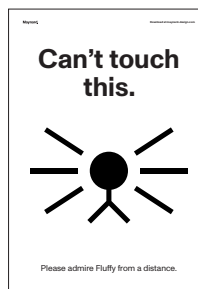

Display in popular dog walking areas.

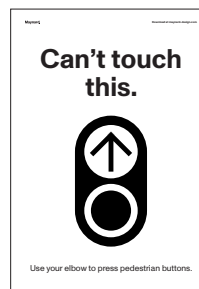

Display at pedestrian crossings.

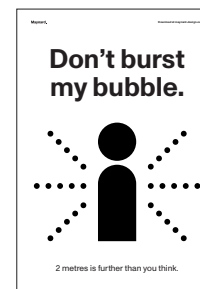

Display in high foot-traffic areas.

#### How to use this toolkit:

**Step 1:**  
Printing the posters

- Print at 100% on **A4 paper**, or 200% on **A3 paper**.
- Print all posters on **fluro green paper** for best effect.
- Print all posters on the same paper stock for consistency.

**Tip:** Check your local stationery store for fluro paper delivery.

**Step 2:**  
Identifying the best locations to install

- Place posters where they will have most impact.

For example:

- Place public bench messaging on/by the bench, not at the entrance to the park.

**Tip:** Don't bombard people with too many messages at once. (Max: 3)

**Step 3:**  
Install the posters to weather and last

- Install in sheltered areas where possible.
- Install on the inside of glass where possible.
- Laminate posters if possible for outdoor areas.
- Install straight and cleanly with strong clear or black tape.

**Tip:** Reduce lamination costs and waste by only laminating posters that could get rained on.

**Step 4:**  
Installation best-practice

- Install at eye-level. **1.4m** is the optimum height.

**Tip:** Remove other unimportant posters that distract from Covid-19 messaging.

# Guide

## Recreatable notices

### Don't have a printer?

Use this guide to create your own posters. You will need two toilet paper rolls, a pencil, a black marker, paper and a pair of scissors.

### Create your shapes:

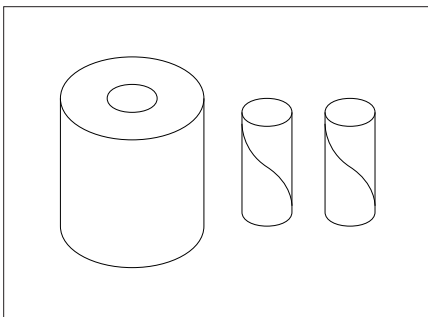

You will need two empty toilet rolls

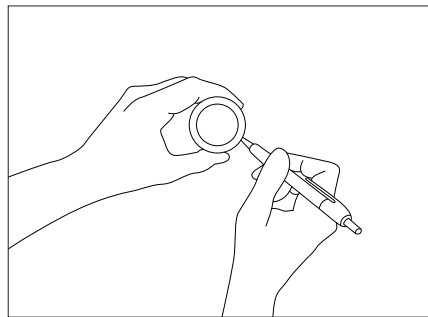

Use one roll to draw circles

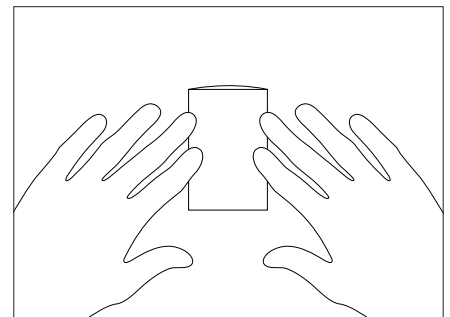

Fold the second roll in half

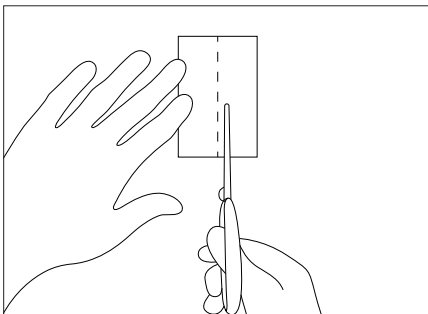

Cut along one of the fold lines

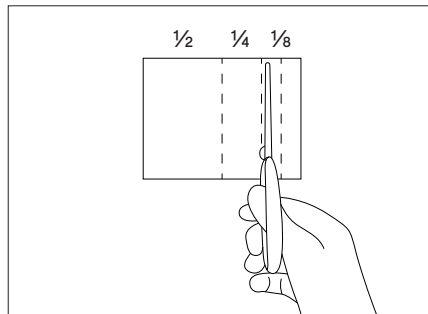

Open and cut into 1/2, 1/4 and two 1/8's

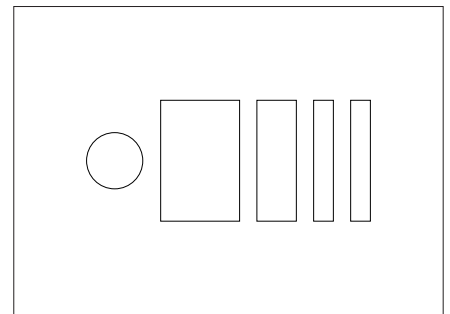

Use these shapes to create pictograms

### How to draw your own posters:

**1. Outline and combine shapes with pencil.**

Leave space for large message

Leave space for small message

**2. Fill in the shapes with a black marker.**

**3. Use the rectangle to align the height of letters.**

Don't burst my bubble.

2 metres is further than you think

**4. Go over the letters to make letters bolder.**

Don't burst my bubble.

2 metres is further than you think

**Bro's stay in  
their codes.**



Stay local.

**Don't sit.  
Good boy.**



The bench is physical distancing, too.

**Don't sit.  
Good girl.**



The bench is physical distancing, too.

# Don't sit. Good human.



The bench is physical distancing, too.

# Can't touch this.

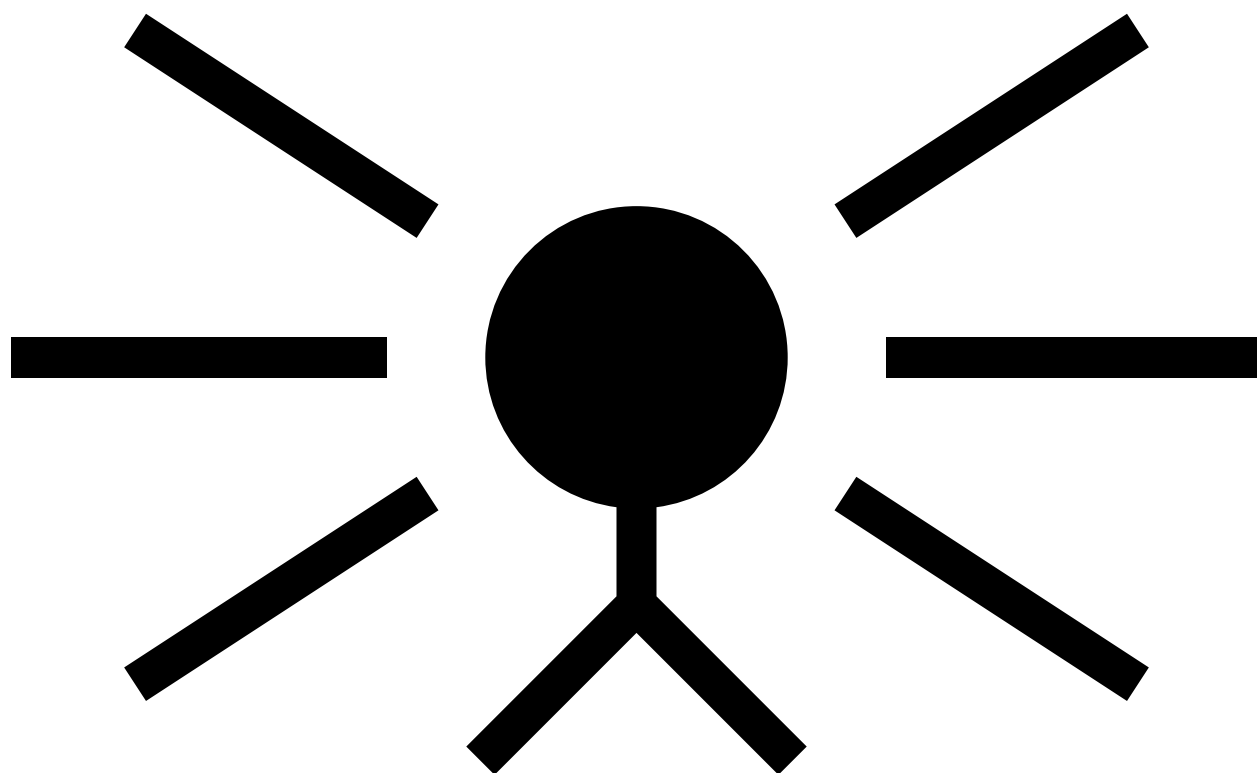

Please admire Fluffy from a distance.

# Can't touch this.

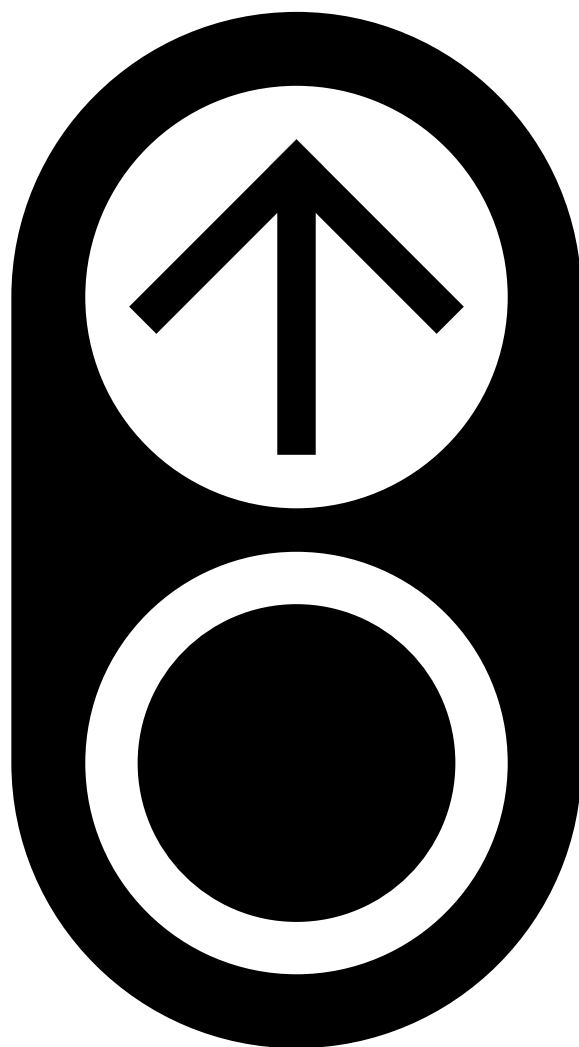

Use your elbow to press pedestrian buttons.



# Don't burst my bubble.

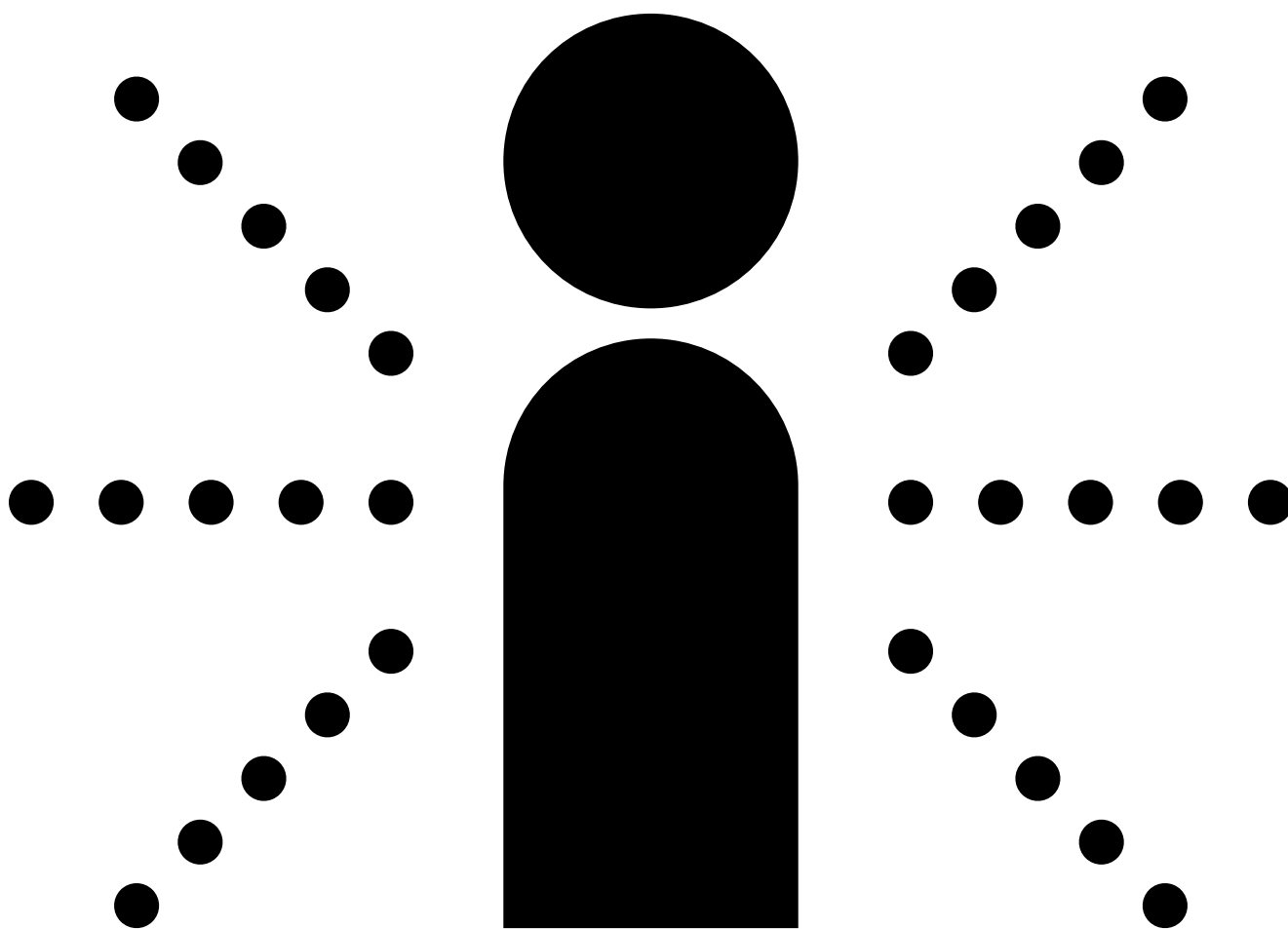

2 metres is further than you think.