

Parks

Covid-19 Toolkit

Covid-19 Guidance Posters

Use this guide to print and install Covid-19 messaging in public parks, beaches and recreational areas.

Posters to print from this toolkit:

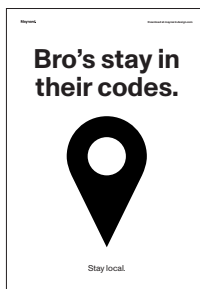

Display in popular destinations.

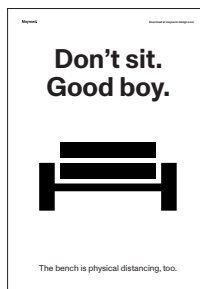

Display on public benches.

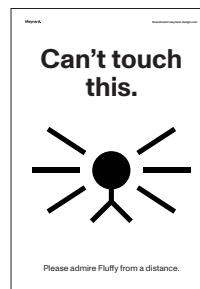

Display in popular dog walking areas.

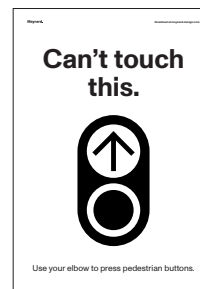

Display at pedestrian crossings.



Display in high foot-traffic areas.

How to use this toolkit:

Step 1:
Printing the posters

- Print at 100% on **A4 paper**, or 200% on **A3 paper**.
- Print all posters on **fluro green paper** for best effect.
- Print all posters on the same paper stock for consistency.

Tip: Check your local stationery store for fluro paper delivery.

Step 2:
Identifying the best locations to install

- Place posters where they will have most impact.

For example:

- Place public bench messaging on/by the bench, not at the entrance to the park.

Tip: Don't bombard people with too many messages at once. (Max: 3)

Step 3:
Install the posters to weather and last

- Install in sheltered areas where possible.
- Install on the inside of glass where possible.
- Laminate posters if possible for outdoor areas.
- Install straight and cleanly with strong clear or black tape.

Tip: Reduce lamination costs and waste by only laminating posters that could get rained on.

Step 4:
Installation best-practice

- Install at eye-level. **1.4m** is the optimum height.

Tip: Remove other unimportant posters that distract from Covid-19 messaging.

Guide

Recreatable notices

Don't have a printer?

Use this guide to create your own posters. You will need two toilet paper rolls, a pencil, a black marker, paper and a pair of scissors.

Create your shapes:

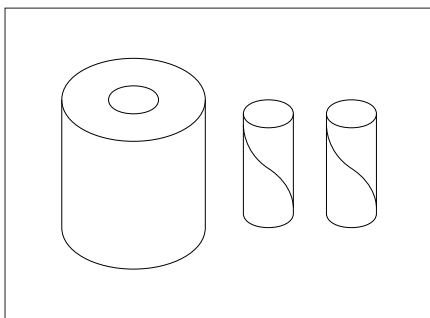

You will need two empty toilet rolls

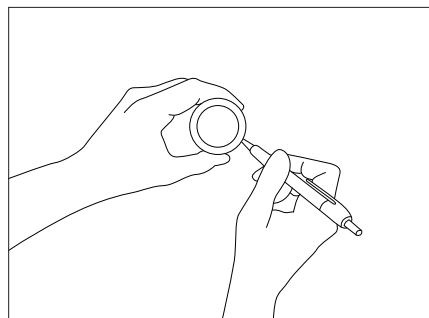

Use one roll to draw circles

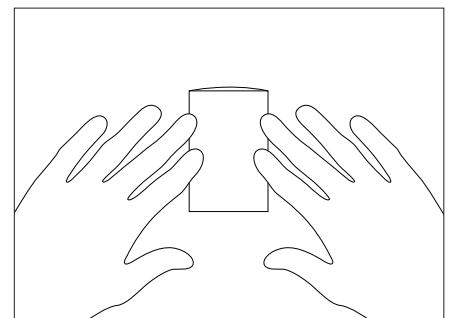

Fold the second roll in half

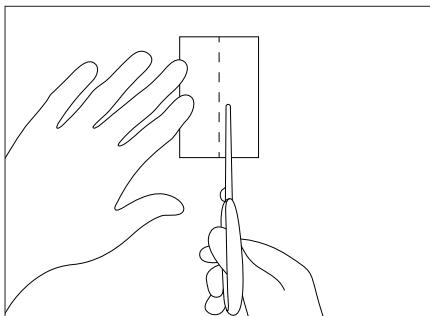

Cut along one of the fold lines

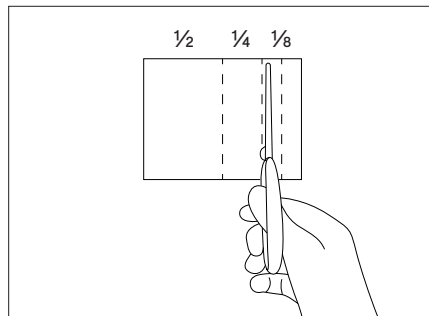

Open and cut into $\frac{1}{2}$, $\frac{1}{4}$ and two $\frac{1}{8}$'s

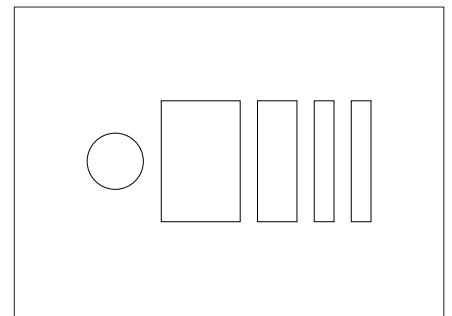

Use these shapes to create pictograms

How to draw your own posters:

1. Outline and combine shapes with pencil.

Leave space for large message

Leave space for small message

2. Fill in the shapes with a black marker.

3. Use the rectangle to align the height of letters.

Don't burst my bubble.

2 metres is further than you think

4. Go over the letters to make letters bolder.

Don't burst my bubble.

2 metres is further than you think

Bro's stay in their codes.



Stay local.

**Don't sit.
Good boy.**



The bench is physical distancing, too.

**Don't sit.
Good girl.**



The bench is physical distancing, too.

**Don't sit.
Good human.**



The bench is physical distancing, too.

Can't touch this.

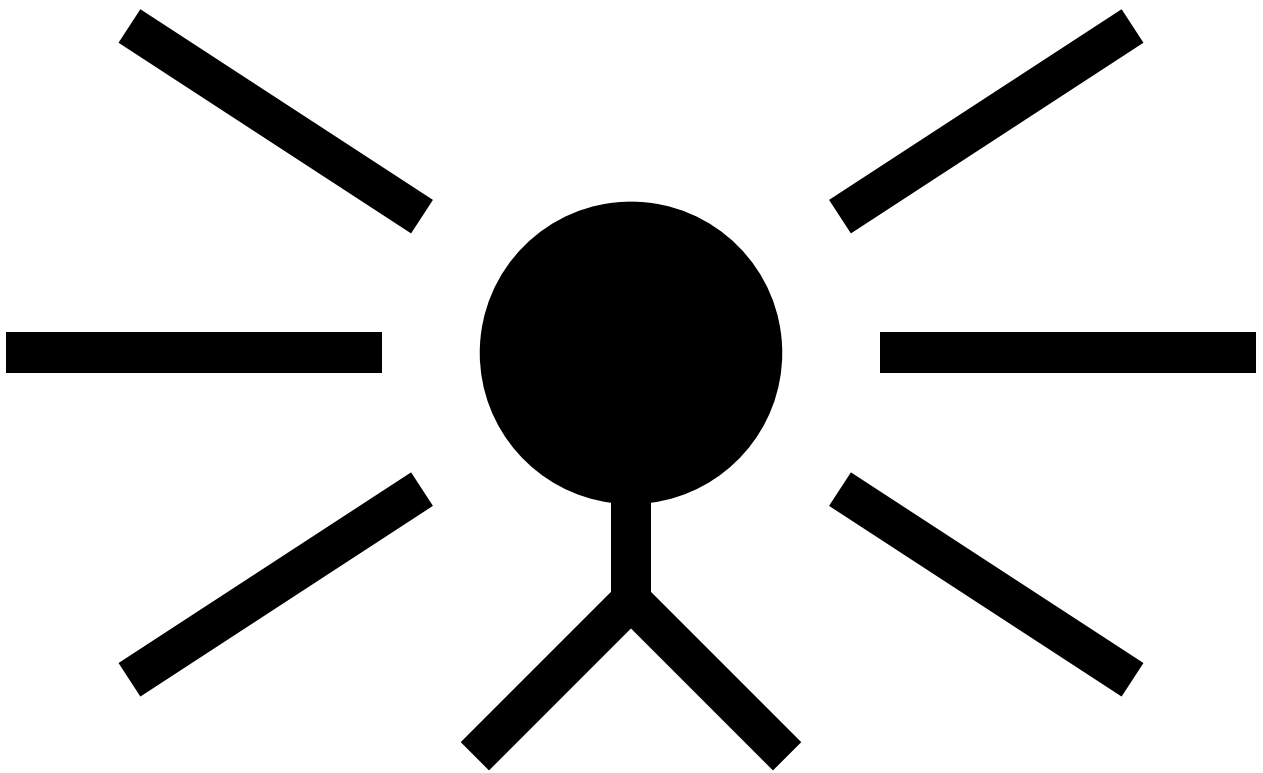

Please admire Fluffy from a distance.

Can't touch this.

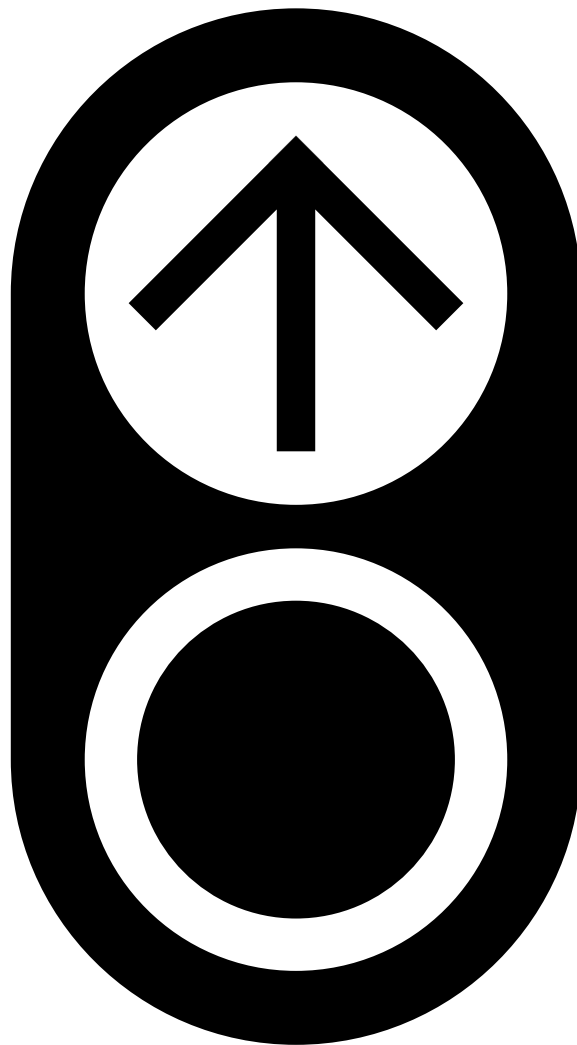

Use your elbow to press pedestrian buttons.

Don't burst my bubble.

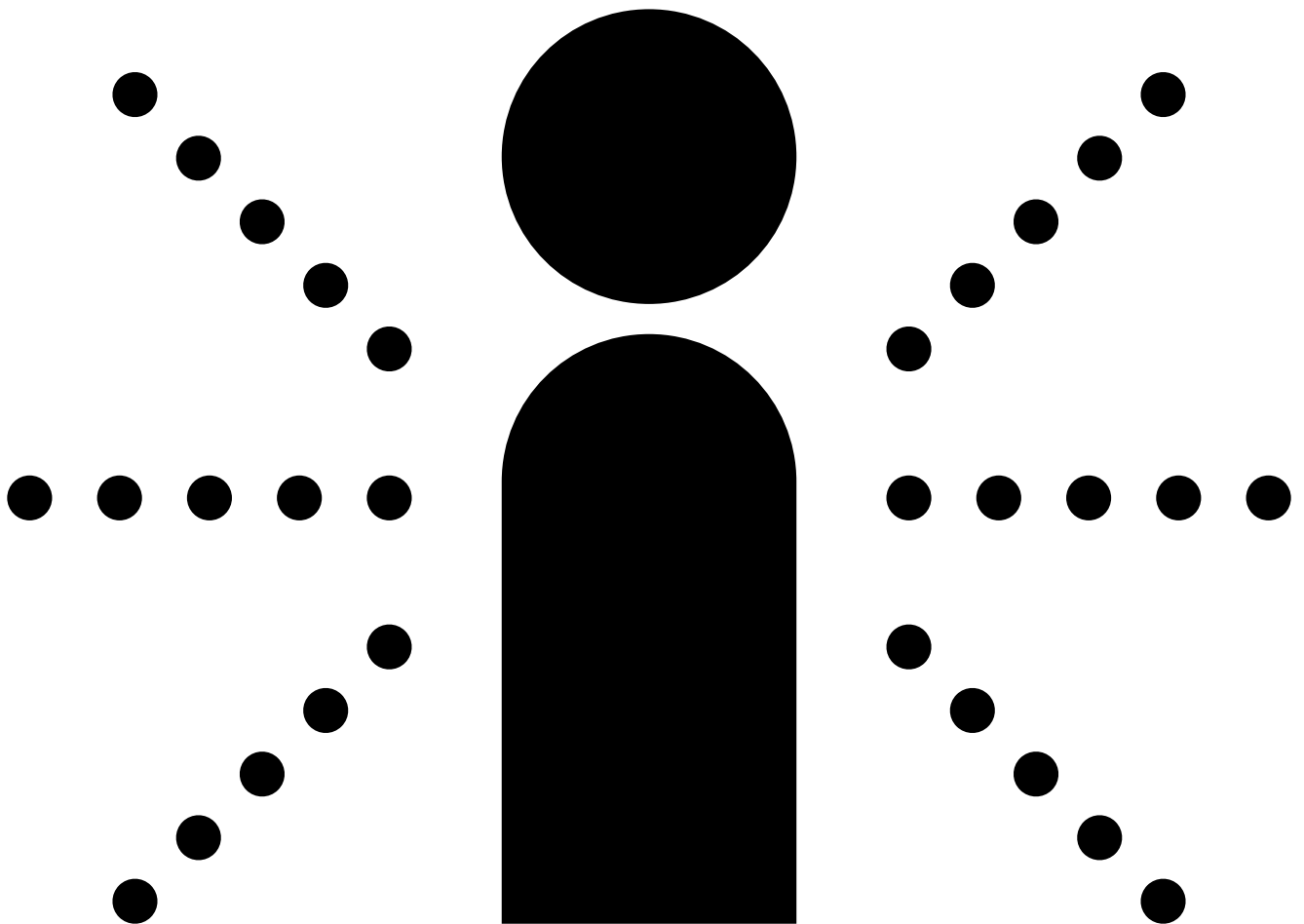

2 metres is further than you think.